

Wind vane

425

Datasheet

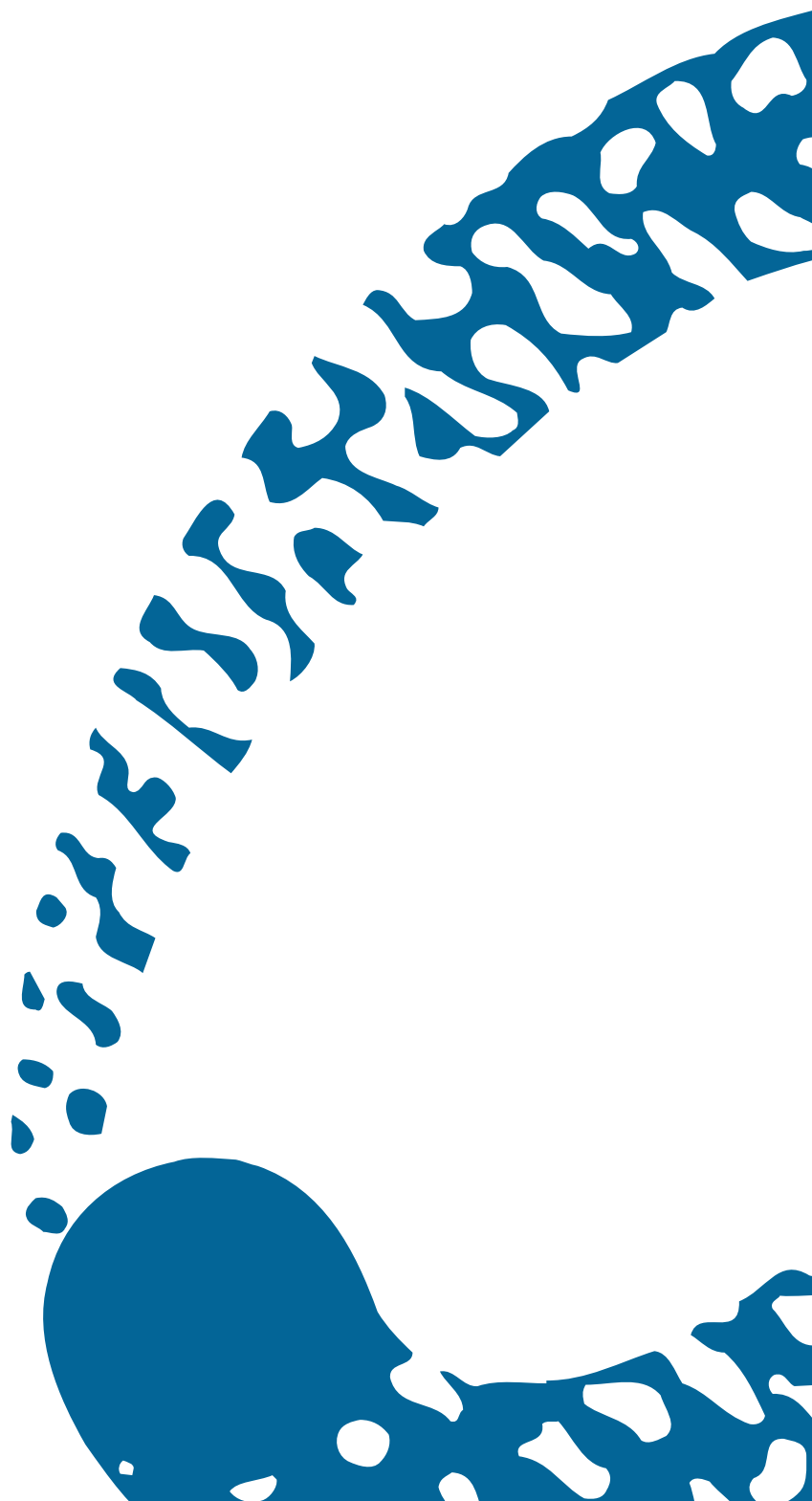

Key Features

- Opto-electrical sensor
- Two PNP digital outputs
- Robust and long-term durability performance (brass/stainless steel)
- Prepared for heating unit
- Short circuit protected
- Start wind >1,5 m/s
- Black/white detection
- Out of wind detection



Wind vane

The Orbital standard wind vane is designed in 1990. It gives you precise measurements of wind direction for yaw regulation of wind turbines. The wind vane is created in high quality brass and does not need calibration.

This wind vane model is used in wind turbines for yaw control and 90° detection.

Specifications

Standards

Area	Standard	Title
	DS/EN 50081-2:1994	Electromagnetic compatibility - Generic emission standard - Part 2: Industrial environment
	DS/EN 61000-6-2:1999	Electromagnetic compatibility (EMC) - Part 6-2: Generic standards – Immunity for industrial environment

Power Specifications

Area	Variable	Value
Power supply	Input voltage	24 VDC (min. 16.0 VDC – max. 32.0 VDC)
	Input current	0,05 A _{max}
Power consumption		20mA

General

Area	Variable	Value
General	Manufacturer	Orbital A/S
	Module type	Wind vane
	Model type	425
	HW-version	1.00
Environment and surroundings	Operating temperature range	-20..+50°C
	Storage temperature range	-40..+70°C
	Start wind speed	1,5 m/s
Sensor principle		Relatively
Cable connection (colour and function)	Interface standard	4-wire shielded cable
	White	+24 VDC (+)
	Brown	Output-signal 1 (in wind)
	Yellow	Output-signal 2 (90° out of wind)
	Green	0 VDC (-)
Output signal	Black	Shield (is connected inside wind vane)
	Output type	PNP
	Number of outputs	2
	Maximum output current	0,035 A _{max}
Direction signal	Short circuit protected	
	Arrow direction *)	Output signal
	Right	High (18 VDC)
	Left	Low (floating)

*) With the socket recess/mounting bolt against the wind.

Mechanical Data

Area	Variable	Value
Materials	Housing	Brass (Cu Zn39Pb3)
	Top	Stainless 18/8 Steel (AISI 304)
	Bearings	Low friction precision steel bearings, on top semi-closed with special seal.
Cable	Cable type	Shielded PVC LIYCH, 4 x 0,25 mm ²
	Cable diameter	5,0 mm
Screwed connection	Material	Stainless 18/8 Steel
	Type	M12, 50.616M/EMV, (EMC)
Weight		0,7 kg
Transport container	Dimensions (L x H x W)	278 x 185 x 217 mm
	Material	Expanded polystyrene
	Total weight	1,15 kg

Working principle

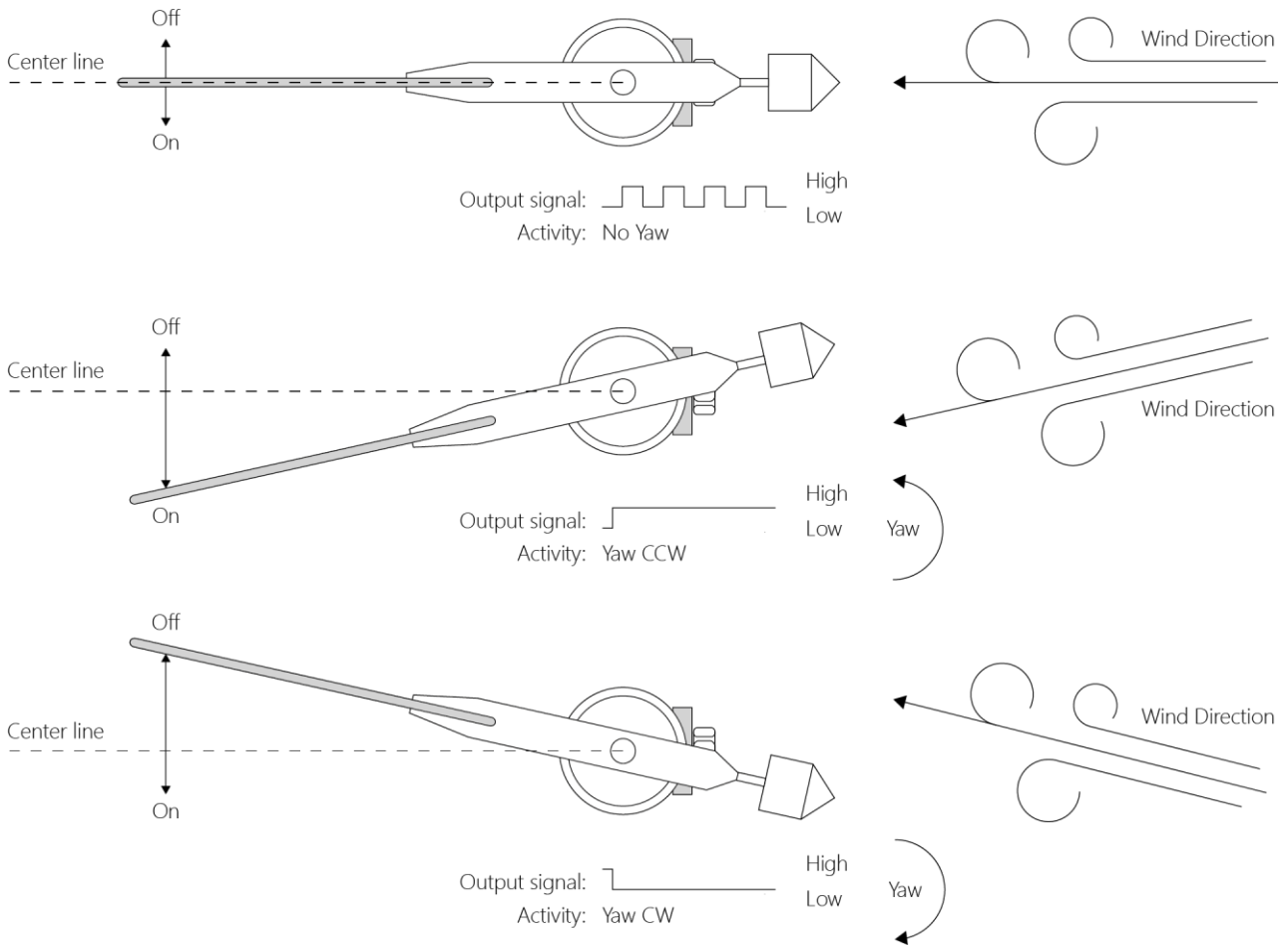

Direction indication

If the wind vane is correctly mounted with the socket recess/mounting bolt pointing towards the wind this illustration defines the signals and direction.

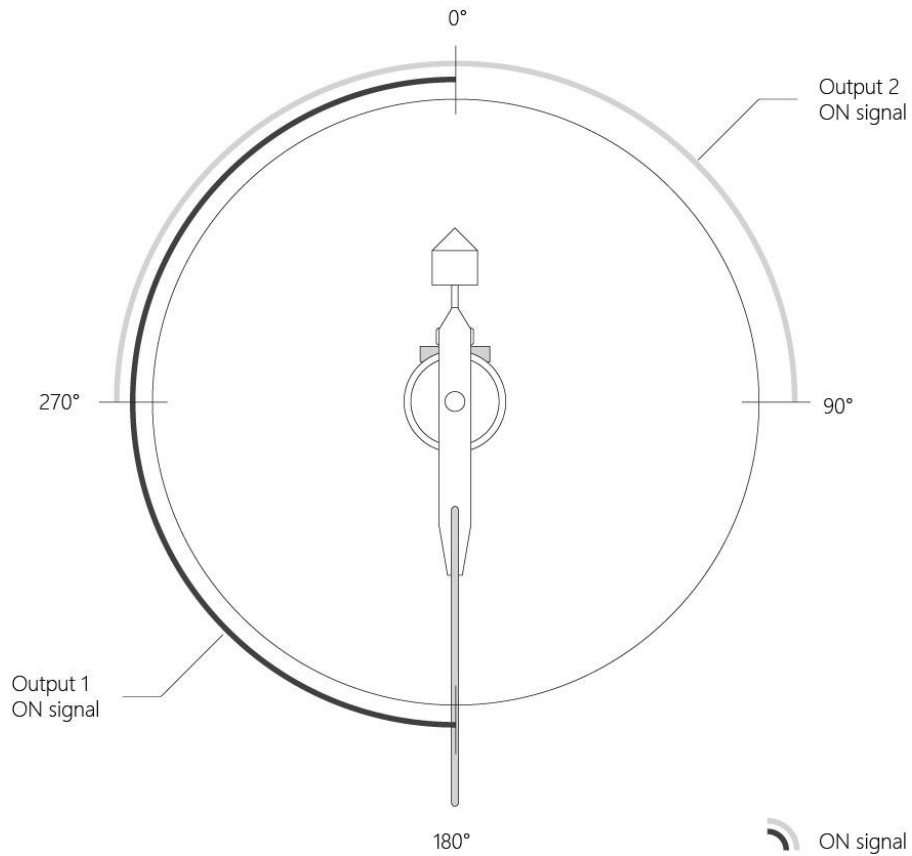

Installation instruction

Mechanically mounting

Mounting vertically and with the socket recess/mounting bolt against the wind turbine front. See illustration below.
(M12 mounting bolt (Stainless steel))

Attention: Please follow the instructions above. Do NOT remove the wind vane from the shaft. Reduced lifetime and bad calibration will be the result.

Mounting base must be connected to earth/chassis.

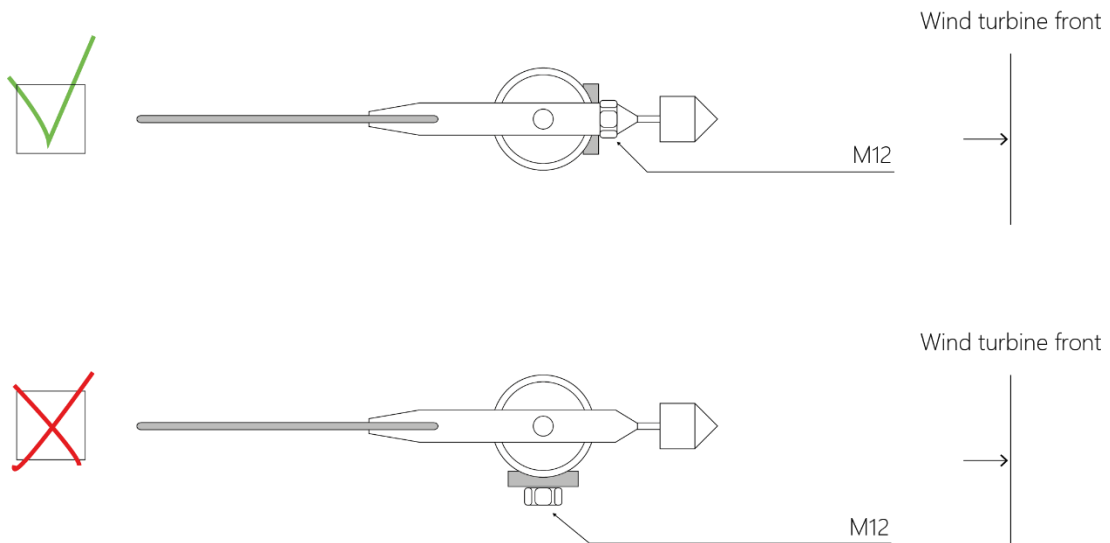

Service instruction

During service it is highly recommended to encapsulate/cover the wind vane to prevent water ingress. The illustration below shows where it is critical if water passes into the enclosure.

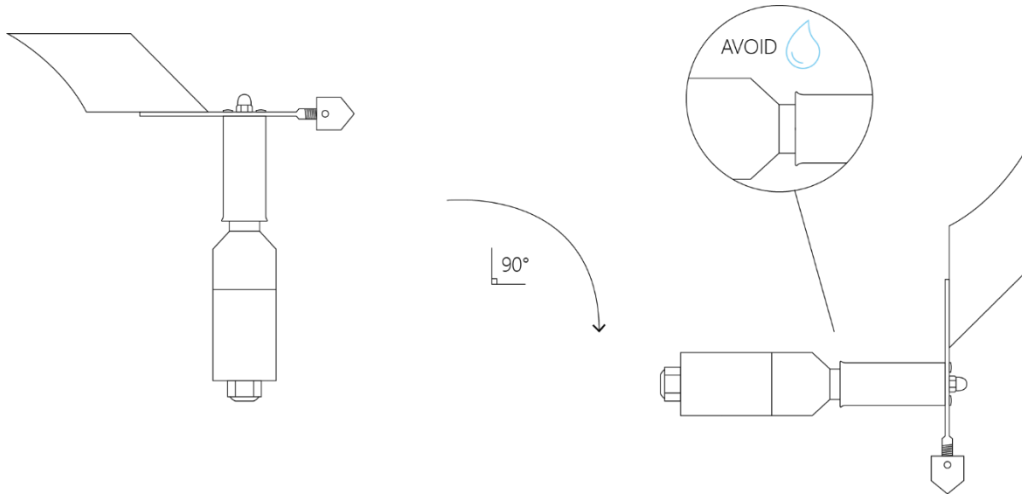

Mechanical Dimensions

The following drawing is not shown in the actual scale.

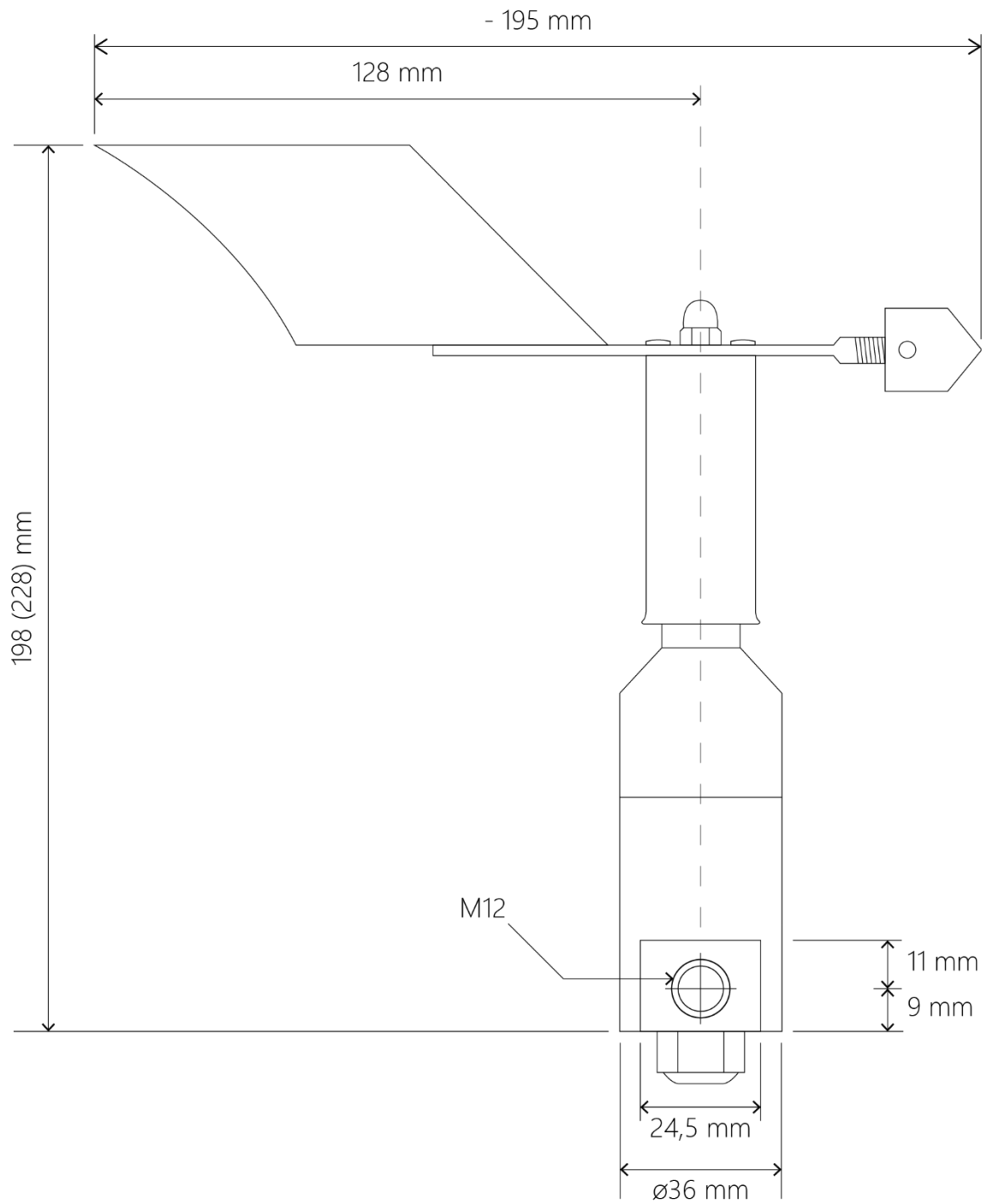

Changelog

Date	Revision	Author	Change
07/03-18	1.1	MKM	Layout change and minor corrections

Copyrights

This document does NOT include safety or installation instructions! Please see the relevant manuals for further details include safety instructions!

Please note that this document may be changed without prior notice. For newest revision, please contact your wind turbine distributor or contact Orbital A/S directly. Contact details can be found at orbital.dk or see last section in this document.

Copyright © 2017 Orbital A/S

All rights reserved.

All brand and product names used in this manual are trademarks or registered trademarks of the respective titleholders.

The information contained in this manual is the property of Orbital A/S. This manual and extracts thereof may only be duplicated or forwarded to third parties following explicit written approval by Orbital A/S.

We reserve the right to make changes and improvements to this manual as well as the hardware and software features at any time and without prior notification. All product names used in this manual are trademarks or otherwise protected by law, even if not specifically indicated.